

HOT KNIFE CR

CutRite

CAUTION

- Please read these instructions carefully before operation.
- Take special care on safety prompts in these instructions so as to avoid injury to yourself, other people and objects.
- Please follow the guidelines in these instructions to avoid damage to the tool.

Recommended Use

Expanded Polystyrene (EPS), Extruded Polystyrene (XPS), Polyethylene, Cross-Linked Polyethylene, Polypropylene, and many other foamed plastics and materials can be easily cut with this Hot Knife CR™. Check with the foam manufacturer for safe and proper cutting procedures.

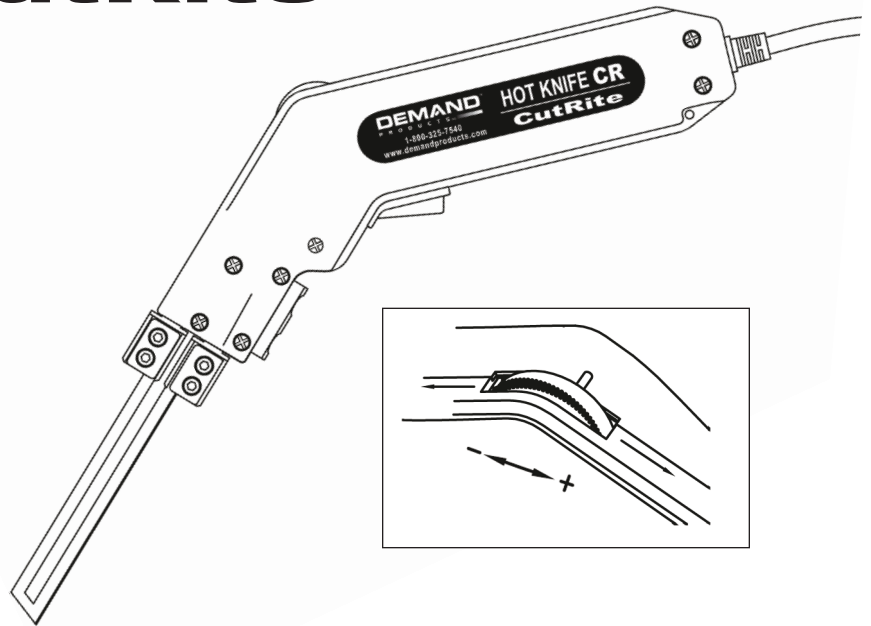

BLADE INSTALLATION:

NOTE: Always unplug the power cord of the Hot Knife CR™ before installing or removing the blades. Allow sufficient cooling time for blades, blade holders and mounting crews before handling.

Straight Blade:

1. Loosen the screws on the blade holders with the wrench.
2. Slide the blade under the square pressure plates until snug.
3. Securely tighten screws to assure the proper electrical connection. Do not over-tighten.
4. Once the blade is firmly in place, plug your Hot Knife CR™ Unit into a standard 120 volt power supply.
5. The temperature control knob has 16 click setting stops that correspond to the graduated ridges on the surface. The smaller the ridge the lower the power setting.

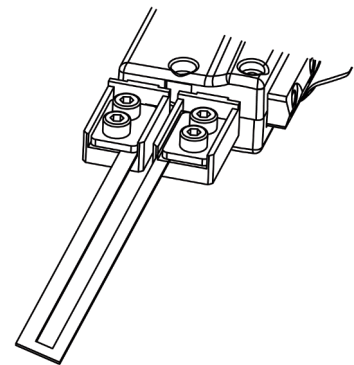

CAUTION:

- The Hot Knife CR™ blades have a sharpened razor edge, for the cleanest cut always cut in the direction on the sharpened edge.
- Excessive power output and heat generation may cause the blade holders to overheat resulting in damage to the unit. Use only the power output for proper cutting. The blade does not need to be red hot to move through foamed plastics.

Attachments:

SLED

The sled enables you to make thousands of different shapes and elaborate cuts by using our NFWF blade material. It can be shaped with our WCP wire bending pliers.

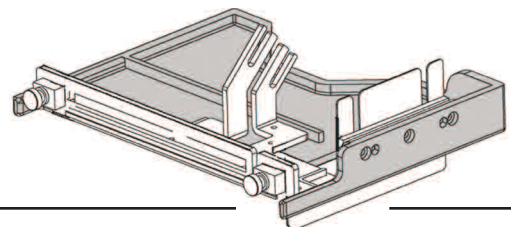

HOT KNIFE CR

CutRite

Operation:

Put your temperature control knob at the midrange setting, place the blade against the edge of the foam and depress trigger. Optimum cutting should be virtually smoke free.

NOTE: For the best results, practice on scrap pieces of foam.

When cutting foam it is best to keep the temperature and speed consistent. If smoke develops during the cut, you are cutting too slow or the blade is too hot which could result in an oversized, uneven cut. This can be remedied by lowering the temperature and intermittently releasing the trigger during your cut. As the cutting resistance increases, depress the trigger again. Your Hot Knife CR™ will reach the set temperature within seconds. You can accomplish your cut with minimal smoke by using this process. Cutting in this manner will also prolong the life of the knife.

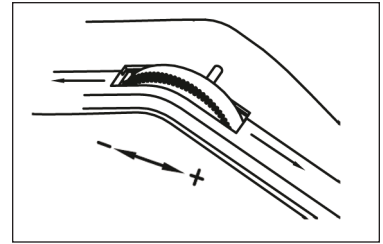

Releasing the trigger approximately one or two inches prior to the completion of the cut will help keep the blade clean and free from buildup

The selected cutting blade should not be longer than 3/4" past the thickness of your foam board. The foam cools the blade as it cuts. The exposed portion can overheat and cause your blade to warp.

Specifications:

Input: 120 Volts
Output: 150 Watts
Weight: 10 Ounces
Length: 10¹/₄ Inches
Width: 2 Inches
Temperature: 600°+

Maintenance:

Constant use of the Hot Knife CR™ may result in polystyrene material build up on blades and the brass holders. This excess polystyrene interferes with the proper electrical and impairs the performance of the blades. The brass blade holders and blades can be thoroughly cleaned with a wire brush.

Guidelines and Cautions:

- Consult foam manufacturer's MSLS sheet for flash points and toxicity of material you will be cutting.
- Always operate the Hot Knife CR™ in well ventilated space
- Never burn off excess residue on the hot knife blade. The blades will overheat, warping the blade and potentially overheating the Hot Knife CR™.
- Only operate Hot Knife CR™ when it is in contact with the insulation board.
- Keep hot blades away from skin, clothing and other flammable materials.
- Allow blades to cool before handling. A hot blade may cause injury or burns to exposed surfaces.

Limited Warranty

The Hot Knife CR™ Tool is warranted to be free of defects in material and workmanship under normal use for a period of 6 months from the date of purchase.

Liability is limited to repair or replacement of material found defective, free of charge F.O.B. Atlanta, GA. Unauthorized repairs, modifications, or replacements will not be subject to factory warranty.

Except as contrary to State or Federal laws, Demand Products, Inc. shall not be liable to any party for loss, injury or damage, whether direct, indirect or consequential arising out of or the inability to use the equipment or other products made, repaired or sold by Demand Products, Inc. or any of its distributors.